



A midsize V-6 with advanced technology and a proven history of reliability

Vortec 4.3L V-6 Industrial Engine

Features & Benefits

- Designed to use gasoline, propane gas and natural gas
- Cracked powder metal connecting rod to more accurately position the cap to the rod during engine assembly
- Roller valve lifters and roller rocker arms for reduced friction and improved fuel economy
- Nodular iron crankshaft has undercut and rolled fillets for durability
- Counter-rotating balance shaft for smooth performance and low noise
- Composite rocker arm cover for noise reduction
- Timing chain tensioner maintains optimal chain tension for the life of the engine
- Lead-free main bearings and balance shaft rear bearing
- 58X crankshaft position encoder with digital sensor to ensure accurate ignition timing throughout the operating range
- Cylinder block incorporates the following new features:
 - Dual flat response knock sensor bosses
 - Revised bolt pattern for new front cover
 - Threaded block heater/drain hole - left side
- Cast aluminum front cover epoxy painted for corrosion protection
- Cast aluminum oil pan for increased strength and noise reduction



The Vortec 4.3L V-6 engine features overall size and weight advantages with superior power-to-weight ratios and proven durability.

Available Options

- An electronic control module (ECM) for optimizing fuel and spark requirements is available in kit form (gasoline only)
- Integral Air Fuel Module (IAFM) two-piece inlet manifold with electronic throttle body and high voltage switch (HVS) distributor with ignition coil
- Heavy-duty cylinder heads with exhaust seat inserts, induction hardened inlet seats, and low load valve springs

Vortec 4.3L Feature Focus

GM Powertrain takes its expertise in designing outstanding Vortec truck and SUV engines and leverages it to make sophisticated yet extremely durable industrial engines. In addition, the well-recognized Vortec brand name by itself has become a valuable selling tool for OEMs.

Hydraulic roller valve lifters and roller rocker arms help provide smooth, quiet and efficient operation.

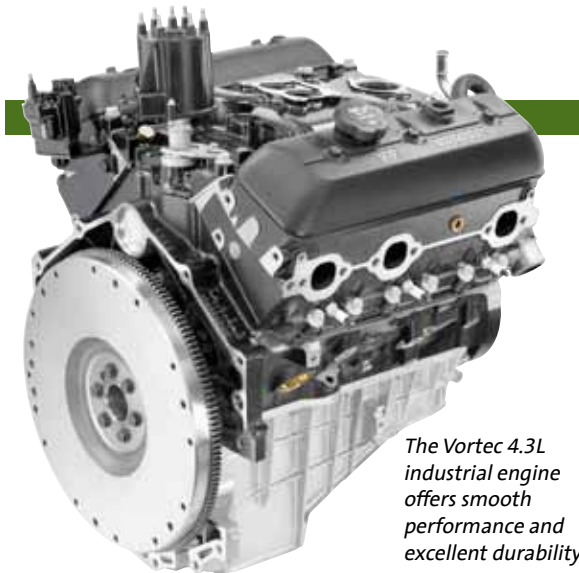
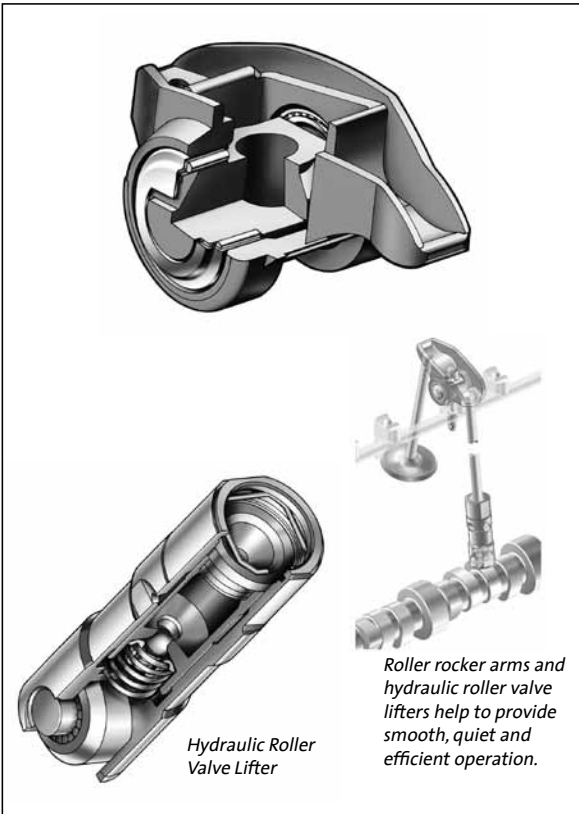

All GM industrial engines are Vortec engines. Vortec means uncompromised power — outstanding power with no sacrifice in fuel efficiency or durability and very little required maintenance.

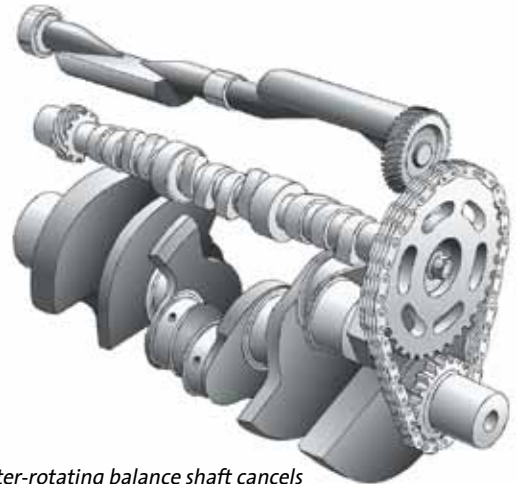

A counter-rotating balance shaft cancels the primary engine vibrations found in 90° V-6 engines. The result is smooth performance and low noise.

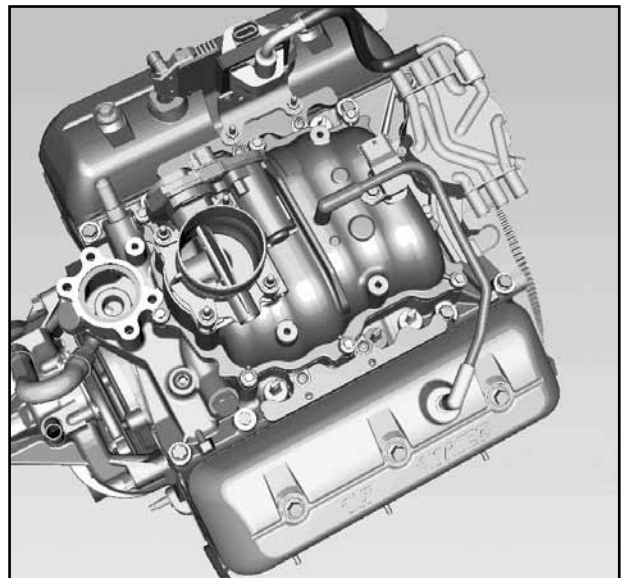

The Integral Air Fuel Module (IAFM) incorporates several components into one assembly. The bottom of the inlet manifold is made of iron and the top is made of aluminum. Integrated into the module is an electronic throttle body. Also included is a combination manifold absolute pressure (MAP) and manifold air temperature (MAT) sensor.

Specifications

Type: 4.3L V-6 Gen 1e

Displacement: 262 cid (4.3L cc)

Engine Orientation: Longitudinal

Compression Ratio: 9.4:1

Valve Configuration: Overhead Valves
(2 valves per cylinder)

Assembly Site: Romulus, Michigan

Valve Lifters: Hydraulic Roller

Firing Order: 1-6-5-4-3-2

Bore x Stroke: 101.60 x 88.39 mm

Bore Center: 111.76 mm

Bore Area: 486.44 cm²

Fuel System: OEM Defined

Fuel Type: Regular Unleaded

Propane and Natural Gas

Horsepower:

190 hp (142 kW) @ 4400 rpm (Gasoline)

183 hp (136 kW) @ 4000 rpm (Propane)

164 hp (122 kW) @ 4000 rpm (Natural Gas)

Torque:

253 lb-ft (343 Nm) @ 2800 rpm (Gasoline)

247 lb-ft (335 Nm) @ 2800 rpm (Propane)

230 lb-ft (312 Nm) @ 1400 rpm (Natural Gas)

Actual power levels may vary depending on OEM calibration and application.

Fuel Shutoff: OEM Defined

Shipping Weight: 430 lb (195 kg)

Emissions Controls: N/A

Materials:

Block: Cast Iron GM232-M

Cylinder Head: Cast Iron

Intake Manifold: Cast Iron (1-piece)

Cast Iron/Aluminum (2-piece)

Exhaust Manifold: None

Main Bearing Caps: Cast Iron GM232-M

Crankshaft: Nodular Iron

Camshaft: 5150 Steel Billet

Connecting Rods: Powdered Metal

Information may vary with application. All specifications listed are based on the latest product information available at the time of publication. The right is reserved to make changes at any time without notice.

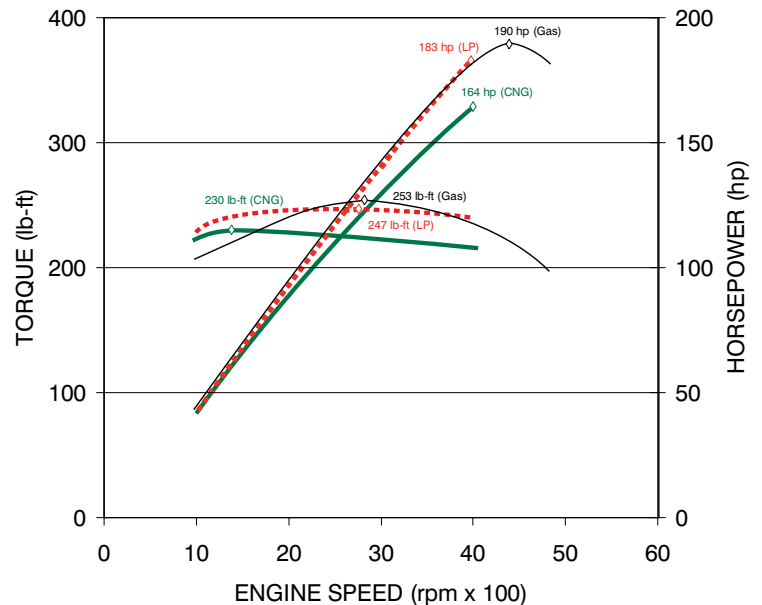

Actual power levels may vary depending on OEM calibration and application.
Plot represents as tested with one-piece manifold

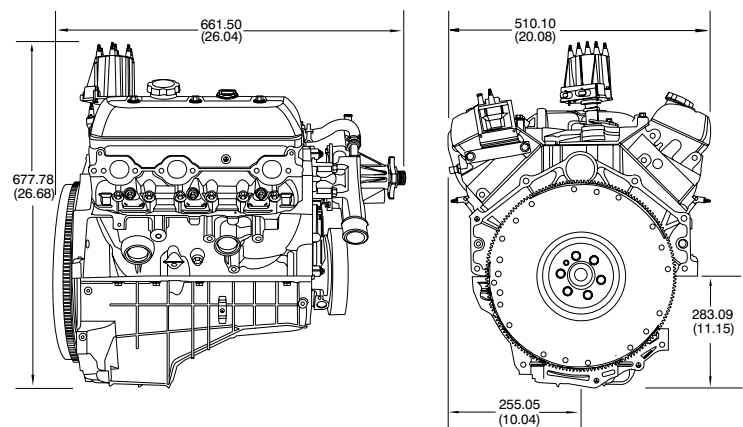

GM Powertrain

www.gmpowertrain.com