



A proven history of performance and durability

Vortec 3.0L I-4 Industrial Engine

Features & Benefits

MPFI Version (LMX):

- Multi-port electronic fuel injection (MPFI) version for gasoline or dual fuel applications
- Cylinder head targets fuel injectors to back of intake valves for quick response to changing conditions
- Stainless steel MPFI fuel rail resists corrosion

Gaseous Version (LW6):

- Customized for gaseous fuels only, taking advantage of the higher octane levels by using a higher compression ratio

All Versions:

- Utilizes 58X crankshaft position sensing via either a VR Crankshaft Position Sensor or a Digital Crankshaft Position Sensor (at OEM choice). Digital Crankshaft Position Sensor enables use of and is compatible with GMPT MEFI Control System. All engines equipped with a HVS (High Voltage Switch) and coil ignition system.
- Sintered powder metal exhaust valve seat inserts for enhanced durability
- Nodular iron crankshaft for increased strength and durability



The 8-port cylinder head configuration of the Vortec 3.0L engine has an MPFI version and a gaseous-fuel-only version.

Available Options

- An electronic control module (ECM) for optimizing fuel and spark requirements is available in kit form (gasoline only).
- Available in low and high compression ratio.

Vortec 3.0L Feature Focus

The Vortec 3.0L is currently used exclusively in marine and industrial applications. Whether on the water or on the job, the Vortec 3.0L delivers the durable power you need.



All GM industrial engines are Vortec engines. Vortec means uncompromised power — outstanding power with no sacrifice in fuel efficiency or durability and very little required maintenance.



The 8-port version cylinder head casting is used on all versions of the Vortec 3.0L engine. Certain versions of this common casting are machined to accept the MPFI Fuel Injection System.

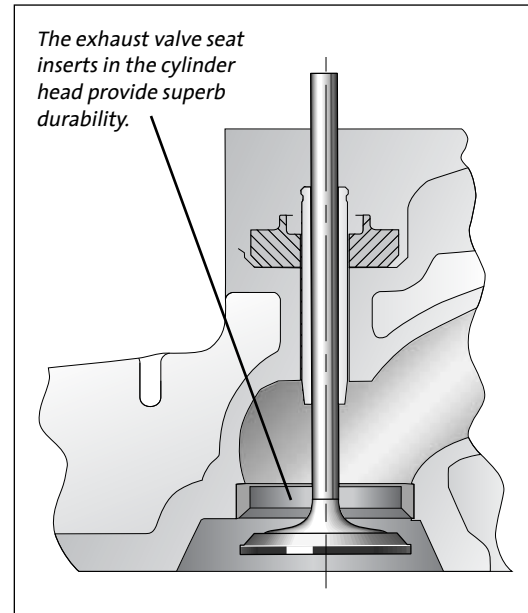

The Vortec 3.0L engine, with the longest history of any industrial engine offered by GM Powertrain, has a well-earned reputation for durability and reliability.

Specifications

Type: 3.0L I4

Displacement: 181 cid (2966.59 cc)

Engine Orientation: Longitudinal

Compression Ratio: 10.5:1 (LW6), 9.2:1 (LMX, High CR)
8.25:1 (LMX, Low CR)

Valve Configuration: Pushrod Actuated
Overhead Valves
(2 valves per cylinder)

Assembly Site: Toluca, Mexico

Valve Lifters: Hydraulic Flat Tappet

Firing Order: 1 - 3 - 4 - 2

Bore x Stroke: 101.60 x 91.44 mm

Bore Center: 112.26 mm

Bore Area: 324.29 cm²

Fuel System: MPFI Fuel Rail and Injectors (LMX)
N/A (LW6)

Fuel Type: LMX: Gasoline (MPFI)
LW6: Propane, Natural Gas

Horsepower:

94 hp (70 kW) @ 3200 rpm (MPFI: Gasoline (LMX))
Low CR

93 hp (69 kW) @ 3.0L rpm (MPFI: Gasoline (LMX))
High CR

73 hp (54 kW) @ 2200 rpm (Natural Gas: (LW6))

64 hp (48 kW) @ 1800 rpm (Propane: (LW6))

Torque:

188 lb-ft (255 Nm) @ 1800 rpm (Propane: (LW6))

178 lb-ft (241 Nm) @ 1600 rpm (Nat. Gas: (LW6))

172 lb-ft (233 Nm) @ 1800 rpm (MPFI: Gasoline (LMX))
High CR

168 lb-ft (228 Nm) @ 2300 rpm (MPFI: Gasoline (LMX))
Low CR

Fuel Shutoff: OEM defined

Shipping Weight: 363 lb (165 kg)

Materials:

Block: Cast Iron

Cylinder Head: Cast Iron with exhaust valve seat inserts

Intake Manifold: Customer Supplied

Exhaust Manifold: Customer Supplied

Main Bearing Caps: 2 - Bolt Cast Iron

Crankshaft: Nodular Cast Iron

Camshaft: Indus. Profile Low Speed, High Torque (8-port)

Connecting Rods: Powdered Metal

Information may vary with application. All specifications listed are based on the latest product information available at the time of publication. The right is reserved to make changes at any time without notice.

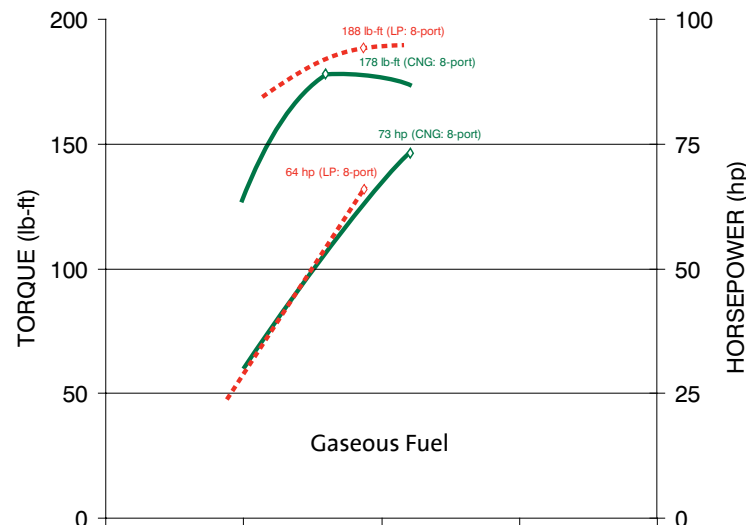
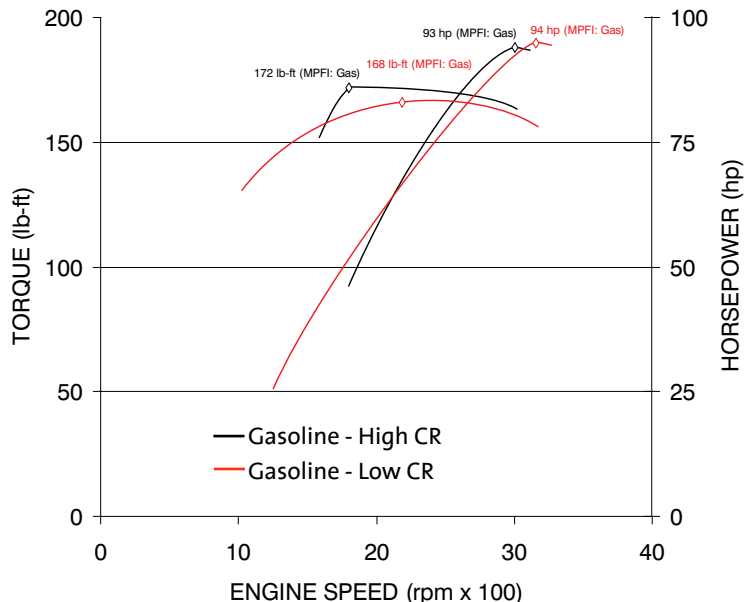

Actual power levels may vary depending on OEM calibration and application.

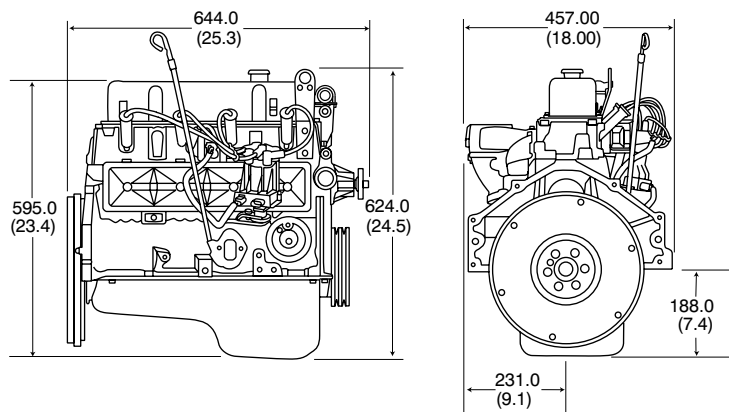

GM Powertrain

www.gmpowertrain.com